

GeoNeurale

announces

Neural Networks Applications

for

Petrophysical and Seismic Attributes Estimation and Integration

GATE – Garching Technologie und Gründerzentrum

Munich

Germany

Neural Network DESIGN Backpropagation Calculation

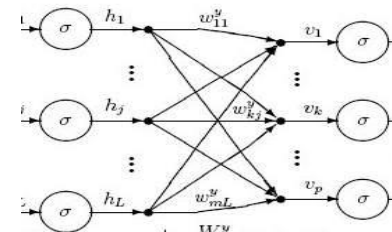
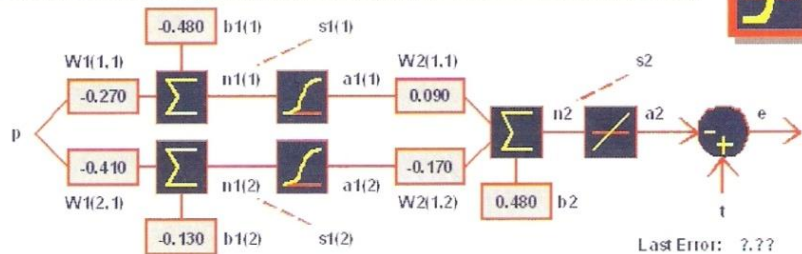

$$\begin{bmatrix} w_1 \\ w_2 \end{bmatrix} = \begin{bmatrix} 0.1 \\ 0.9 \end{bmatrix} + 0.15 * e^{-\frac{1}{2 * 0.74^2}} * \begin{bmatrix} 0.7 - 0.1 \\ 0.6 - 0.9 \end{bmatrix} = \begin{bmatrix} 0.1 \\ 0.9 \end{bmatrix} + 0.15 * 0.4 * \begin{bmatrix} 0.6 \\ -0.3 \end{bmatrix} = \begin{bmatrix} 0.14 \\ 0.88 \end{bmatrix}$$

$$\begin{bmatrix} w_1 \\ w_2 \end{bmatrix} = \begin{bmatrix} 0.9 \\ 0.9 \end{bmatrix} + 0.15 * e^{-\frac{0}{2 * 0.74^2}} * \begin{bmatrix} 0.7 - 0.9 \\ 0.6 - 0.9 \end{bmatrix} = \begin{bmatrix} 0.9 \\ 0.9 \end{bmatrix} + 0.15 * 1 * \begin{bmatrix} -0.2 \\ -0.3 \end{bmatrix} = \begin{bmatrix} 0.87 \\ 0.86 \end{bmatrix}$$

***Neural Networks Applications
for
Petrophysical and Seismic Attributes Estimation
and Integration***

(A course for Geoscientists both as Users and Programmers)

MUNICH

at the

GATE – Garching Technologie und Gründerzentrum

3 DAYS COURSE

INSTRUCTORS: Patrick van der Smagt and Christian Osendorfer

AUDIENCE: Research Geoscientists, Modeling Specialists, Petrophysicists, Seismologists, Geophysicists, Team Leaders, Managers, Scientists involved in Reservoir Characterization, Modeling and Interpretation Systems.

The first two days will be also useful for Scientists of other disciplines who intend to develop their general knowledge of these specific Neural Networks Logic Systems.

COURSE FEES: 2850 Euro plus VAT 19% (The VAT tax will be 100% refunded from the German Ministry of Finances)

ONLINE REGISTRATION: www.GeoNeurale.com

gate

GeoNeurale

Office and Training Location



Campus Garching

gate Garchinger Technologie-
und Gründerzentrum GmbH
Lichtenbergstr. 8
85478 Garching b. München

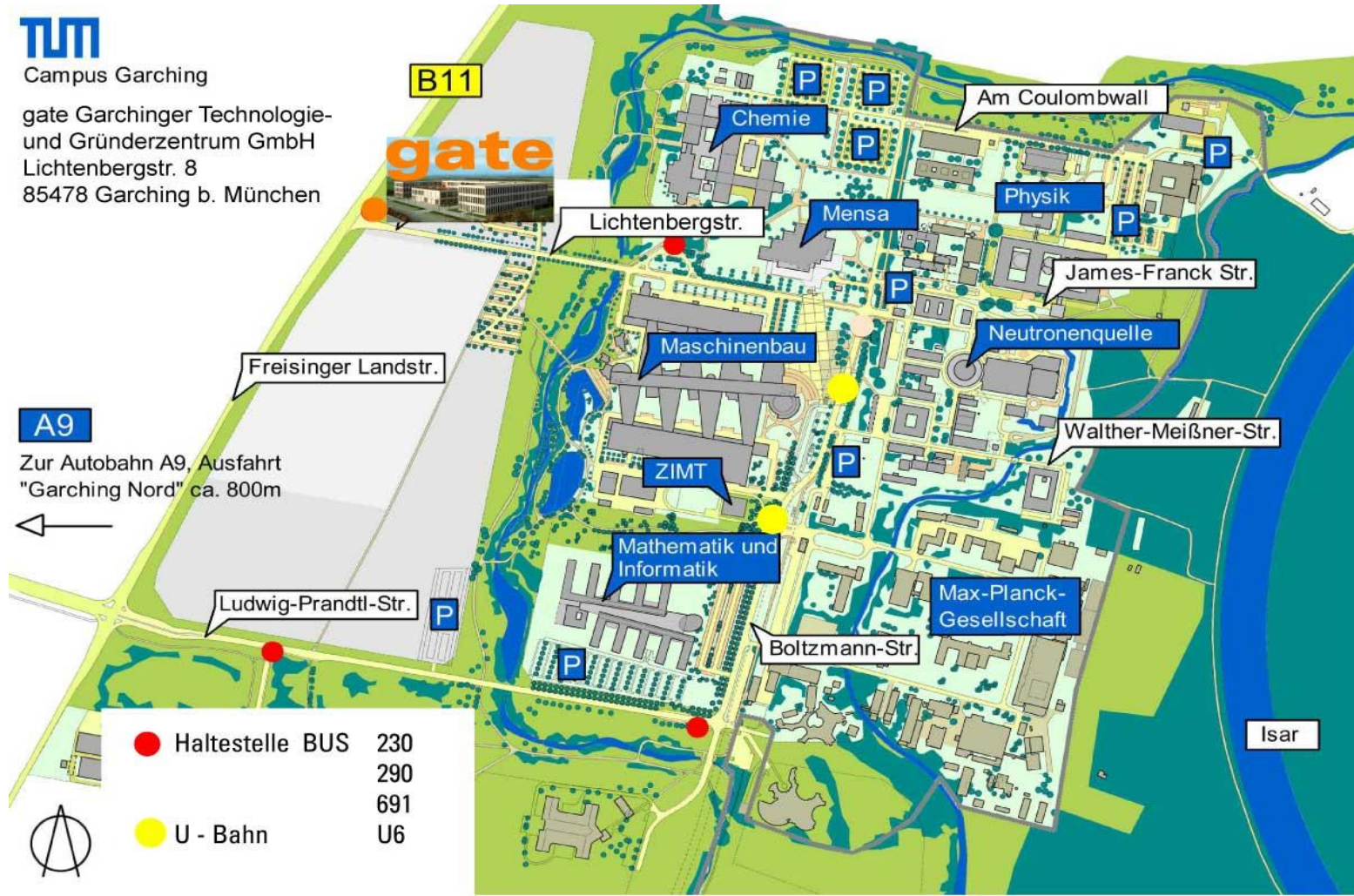

***Neural Networks Applications
for
Petrophysical and Seismic Attributes Estimation
and Integration***

(A course for Geoscientists both as Users and Programmers)

Neural Networks applications will not substitute the deterministic and stochastic approach in the petrophysical and seismic analysis for reservoir characterization but they will be more and more a powerful integration where uncertainty leave open solutions for multiple realizations.

Geoscientists should be aware of the multiplicity of applications and immense capabilities that these logical systems offer as support to the traditional interpretation methods.

This course sets a strong basis in neural networks logical systems and describes the importance and functionality of these methodologies for reservoir characterization purposes.

The Course is developed in 3 days lessons.

The first day will start with an introductions to statistical data pre-processing.

Hebb and Hopfield

The second and third day will deal with the presentation and description of Hebb, Hopfield, Kohonen, Backpropagation Neural Networks and Exercises.

The third day will be concentrated on practical exercises and the participants are encouraged to discuss their own applications and case studies.

The participant will learn the practical use of the Neural Networks applications and also learn, after theoretical and practical training, to test the behaviour of neural Networks with computer programs and to influence their behaviour.

As a practical example, data of the participants can be read from a text file and input in a simple standalone program and processed from a Backpropagation network in order to show the desired output that can be written back to a second text file.

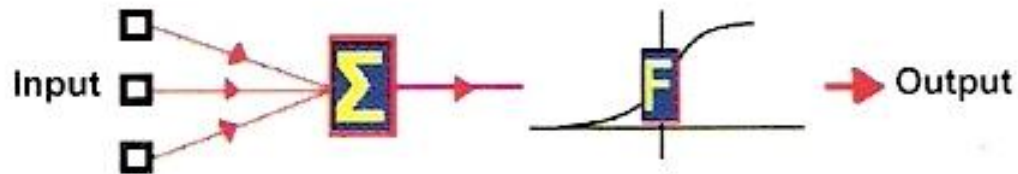

Python and MatLab can be installed in each student's computer to allow her/him to Program and customize her/his own applications to solve the exercises and each individual interpretation problems

PROGRAM

The course provides a strong foundation in the logic of principal types of Neural Networks and particularly those that find an application in the Reservoir Characterization and Interpretations Methods.

The Program is divided into several chapters. Each of them describes a different kind of Neural Network which is then explained in details through exercises and practical applications allowing the participant to interactively learn the principal algorithms, functions and mechanisms ruling all the logical systems.

Day 1

Introductory statistics and Mathematical Methods for data pre-processing applied to neural networks and machine learning

Hours	Topic
1h	Overview of neural networks, some history, some recent
1h	Linear algebra introduction, matrix calculus
1h	Statistics introduction (probabilities, gauss, details about 'real-world' distributions, gamma + student t)
1h	Maximum likelihood estimation, maximum a posteriori estimation
1h	Clustering techniques as first data analysis method
1h	Exercises

Day 2

Machine Learning

Hours	Topic
1h	PCA (principal component analysis), ICA (independent component analysis), latent variables
1.5h	Linear regression and classification recursive least squares, outliers
1.5h	Optimisation and neural networks
2h	Examples in geological and other data and programming examples

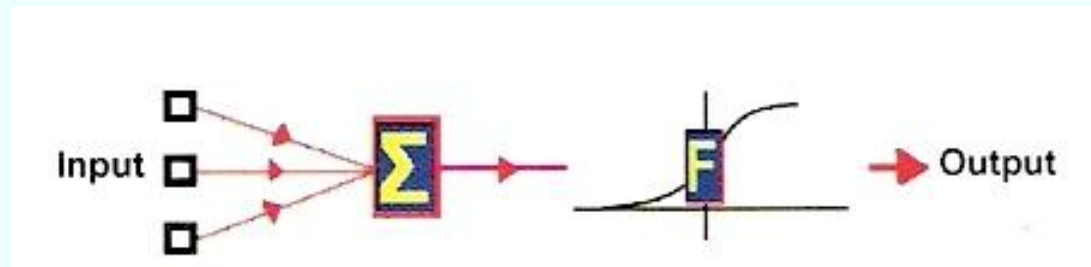

Day 3

Hands-on

Hours	Topic
1.5	More optimisation and neural networks
1	Deep neural networks
1	Unsupervised 'neural' learning
2	Examples in geological and other data and programming examples

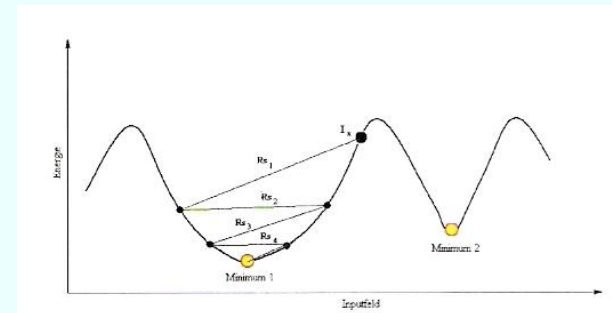
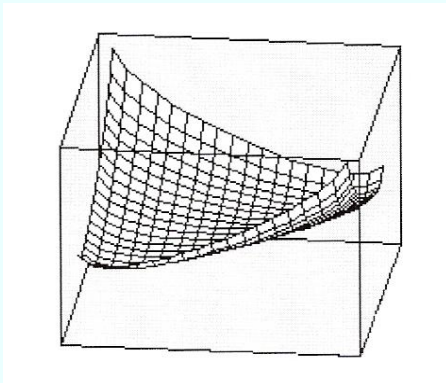

Practical training and exercises

Exercises and practical applications with **Matlab**, **Python** and Applets.

The participants learn to program their own applications in **Python** code and **Matlab**.

The practical part of the course will be also dedicated for short introduction to the **Python** programming language.

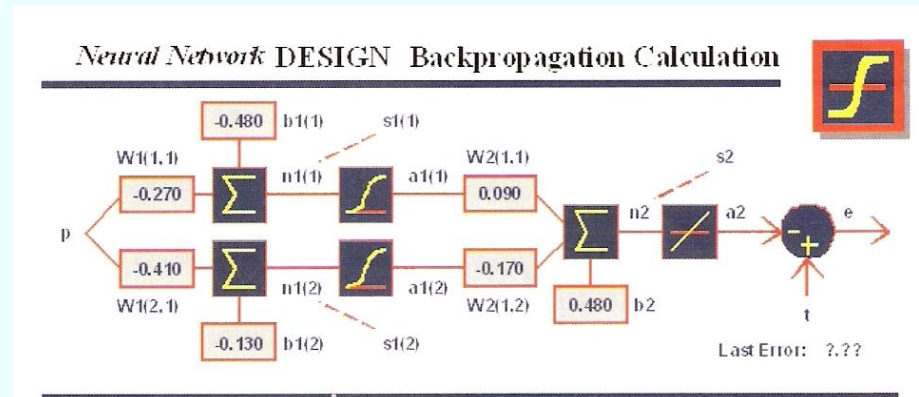
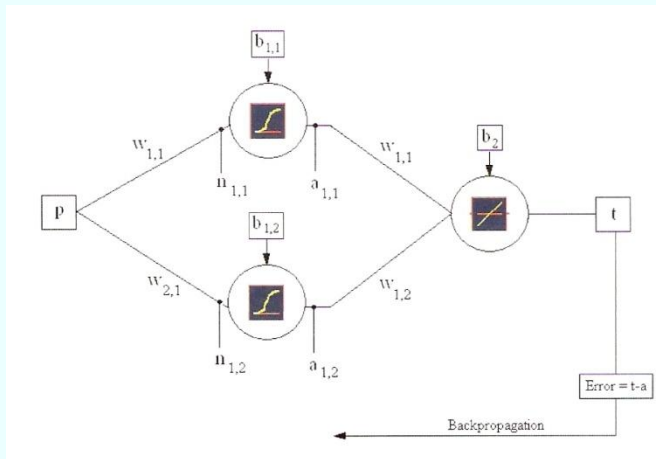

APPLICATIONS TO THE ESTIMATION AND CLASSIFICATION IN THE RESERVOIR CHARACTERIZATION PROCESS

Estimation of Petrophysical Logs

Estimation of Facies , Seismic Attributes

Exercises of real Logs, Facies and Attributes estimation using Python and MatLab

Hopfield Networks and Simulated Annealing:

The Minimum Energy Status

Bayesian Networks

Geostatistical implications

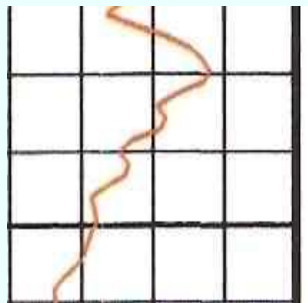
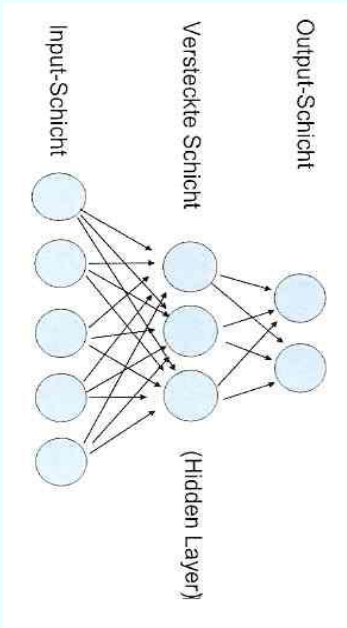
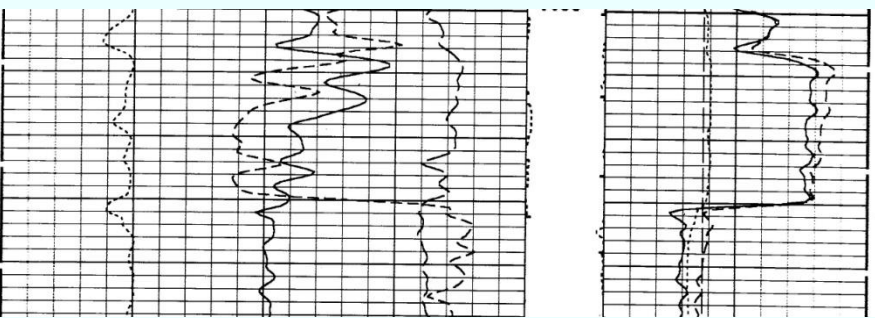
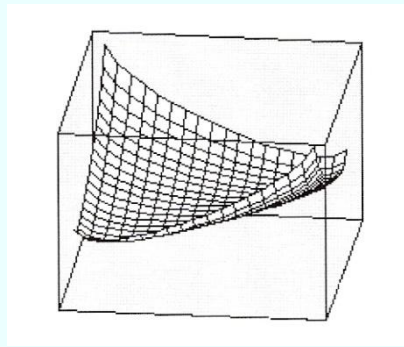

Biography

Patrick van der Smagt

Patrick van der Smagt received his Ph.D. on neural networks applications in robotics in 1995 from the University of Amsterdam. He then moved to the German Aerospace Center, first working on neural network applications in grasping and control, and later on expanding his work to biomimetic robotics, neural control and learning. In 2012 he was offered a professorship on machine learning at the Technische Universität München. Since then he leads two research groups with over 20 researchers, focusing on machine learning, biomechanics, brain-machine interfaces and prosthetics and rehabilitation.

Patrick van der Smagt has published nearly 100 scientific articles, holds over 10 patents and has received over 10M€ third-party funding from the EC and German government. He is editor for various journals and conferences.

Biography

Christian Osendorfer

Christian holds a diploma in Computer Science with a minor in Mathematics. For the past 6 years he has worked with a wide range of machine learning algorithms in different application domains. His focus is currently on unsupervised learning methods and large scale learning problems. Apart from that he likes Optimization, Probability Theory and Linear Algebra and is very fond of programming.

Registration Details

•Course fee: 2850 Euro plus VAT 19%

Payment and Registration

Tuition fees are due and payable in Euro upon enrollment in the course by bank transfer to the bank account given below unless another payment form is agreed

Unless otherwise indicated, the payment should be received before the date specified in the invoice as payment term to make the enrollment effective.

To register to the course please fill in the [registration form](#) and fax or email it along with the confirmation of your bank transfer to:

GeoNeurale

Lichtenbergstrasse 8

85748 Munich-Garching

T +49 89 5484 1

T +49 89 8969 1118

F +49 89 8969 1117

ONLINE REGISTRATION: www.GeoNeurale.com

Bank Information: Genossenschaftsbank EG Muenchen

Bank Account N. 519618

BIC – Code : GENODEF 1M07

BLZ 701 694 64

IBAN : DE19 7016 9464 0000 5196 18

Please indicate your name and the purpose: “Neural Networks course fee ”

www.GeoNeurale.com

Provisions

Tuition fees are due and payable in Euro upon enrollment in the course. Unless otherwise indicated, fees do not include travel costs and living expenses of the participant.

Payments are also accepted via personal or company check, traveler's check, credit card, and Company Purchase Orders.

Cancellations by Participant:

All cancellations are subject to a 100 Euro non-refundable cancellation fee. Cancellations have to be notified to our office, at least 30 days prior to the course start date to receive a refund (less the 100 Euro cancellation fee).

If the participants are unable to cancel prior to the 32 days notification date, they may substitute another person at their place in a course by notifying us prior to the course start date.

Course Cancellations:

GeoNeurale reserves the right to cancel the courses if necessary. The decision to cancel a course is made at least two weeks prior to the course start date. If a course is cancelled, the participant will receive a full reimbursement of the tuition fees (but not of the plane ticket or hotel expenses or any other costs), or will be enrolled in another course upon his decision (the cost of the original course will be applied to the cost of the replacement course).

Before booking any flight or hotel, please wait the written course confirmation on our website. GeoNeurale can not be responsible for any penalties incurred for cancellation or change of flights or hotel reservations.

Refunds:

GeoNeurale will promptly remit all refunds of tuition fees due to cancellations or annulment (less any appropriate non-refundable cancellation fee) within 30 days of the course cancellation.

Force Majeure:

GeoNeurale can not be responsible for cancellations due to "force majeure" events: airplane or airport strikes, emergency situations, natural catastrophes and all situations and incidents independent or outside the human control that can delay or cancel the course. In case of such events related cancellations the course tuition fees will be refunded to the client.

GeoNeurale is not responsible for any delay or absence caused by the training instructor or training instructor company for reasons which are independent or out of the control of GeoNeurale's decisions.

AGREEMENT: Upon enrollment all parties accept the above mentioned provisions. The above specified provisions shall regulate the agreement between GeoNeurale and the participant and the participant company and will enter into force upon enrollment.

REGISTRATION FORM

Please fill out this form and Fax to +49 89 8969 1117

or Email to Courses@GeoNeurale.com

***Neural Networks Applications
for
Petrophysical and Seismic Attributes Estimation
and Integration***

Course Fee: 2850 Euro + 19% VAT

Course Date:

Name:

Company:

Address:

Job Title:

Phone:

Fax:

Email:

SIGNATURE: _____

INFORMATIONS, HOTELS, MAPS, LINKS

TRAINING LOCATION – RESEARCH CENTER

<http://www.geoneurale.com/documents/GATE-Y7.pdf>

GATE GARCHING

<http://www.geoneurale.com/documents/GATE-Y6.pdf>

MAP MUNICH-GARCHING

<http://www.muenchen.city-map.de/city/db/130208000001/14269/Garching.html>

MUNICH INFO and MAP MUNICH CENTRAL

<http://www.muenchen.de/home/60093/Homepage.html>

MAP MUNICH UNDERGROUND

<http://www.mvv-muenchen.de/web4archiv/objects/download/3/netz1207englisch.pdf>

HOTELS NEAR GeoNeurale

<http://www.geoneurale.com/documents/HOTELS-GARCHING.pdf>

BAVARIA INFO

<http://www.geoneurale.com/documents/Around-Munich-Info.pdf>



A school of Geophysics on the Alpine area